

JIS No.0

Japanese Industrial Standards
(JISB4633)

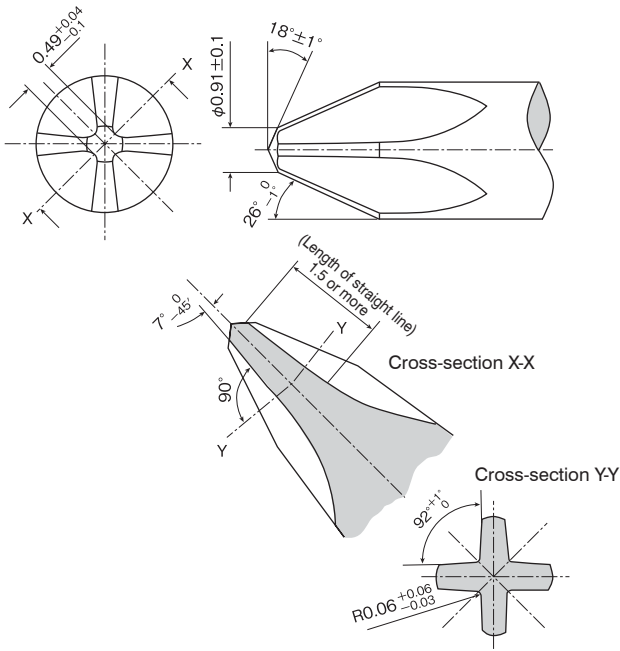

JCIS No.0

Japan Camera Industry Standards
(JICIS9-70)

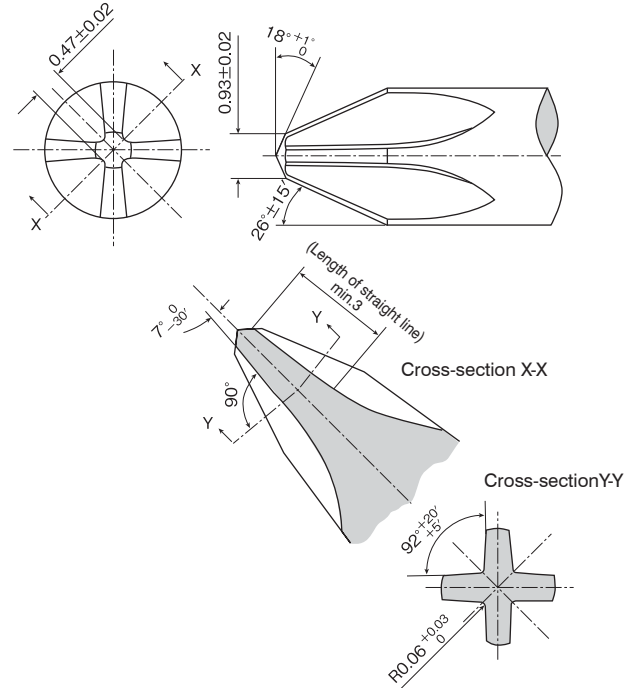

JIS No.1~No.4

Japanese Industrial Standards
(JISB4633)

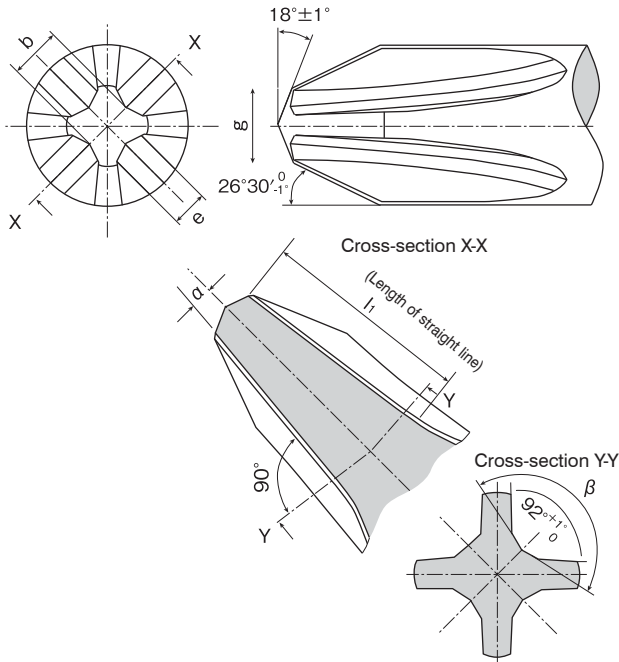

NO.		1	2	3	4
b	Critical dimension	1.001	1.539	2.497	3.574
	tolerance	+0.05 -0.14	+0.07 -0.15	+0.10 -0.17	
e	Critical dimension	0.513	1.102	2.098	2.738
	tolerance	+0.20 -0.10		+0.25 -0.15	
g	Critical dimension	1.270	2.286	3.810	5.080
	tolerance	±0.15		±0.20	
l ₁	Minimum	2.5	3.7	5.2	7.6
α	Critical dimension	7°	5° 45'	5° 45'	7°
	tolerance	0 -45'			
β	Critical dimension	138°	140°	146°	153°
	tolerance	+45' 0			